



OUTSTANDING

- High security post and frame system
- Non-removable fence, highly resistant to vandalism
- Exceptional life
- Complete system
- Low maintenance cost

Application places



Airports Prisons Power stations Personal control Military areas Harbours Warehouses & factories Train stations

Assembly

POST AND ACCESSORIES

- Defence Plus posts have a square cross-section of 80x80x2mm, 100x100x2mm and 120x120x3mm (depending on height).
- The frames are installed using a connecting plate and non-removable safety threaded rods, special brackets or non-removable through threaded rods.
- The posts are made of galvanised sheet metal and plastic-coated with the Rivisa Protecline anti-corrosion coating system.

DEFENCE PLUS PANEL

- The Defence Plus high security panels have the following features.
- Characteristics (see table below).
- They are manufactured with 4mm diameter steel wire and electro-welded joints with a rectangular grid of 12.7x76.2mm.

NOMINAL HEIGHT	LENGTH	EMBEDDING	POST SECTION (mm)	NO. OF SUPPORTS	PANEL MEASUREMENTS	
					LENGTH	HEIGHT
1m80	2m20	0m 35	60x60x2	4 units	2m515	1m829
2m00	2m50	0m 35	80x80x2	5 units		2m112
2m50	3m00	0m 50	80x80x2	8 units		2m442
2m70	3m20	0m 50	80x80x2	8 units		2m658
3m00	3m60	0m 60	100x100x2	10 units		3m001
4m00	4m60	0m 60	120x120x3	11 units		4m001

* Please contact us for more finishing options

Assembly

DEFENCE PLUS SUPPORT OPTION

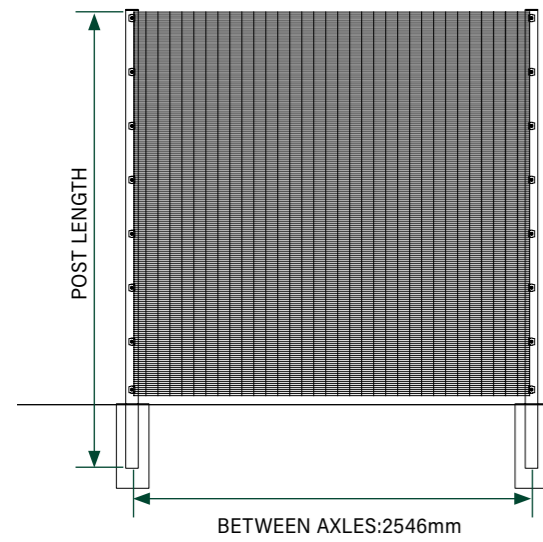

OPTION FOR THROUGH BOLTS AND PLATES

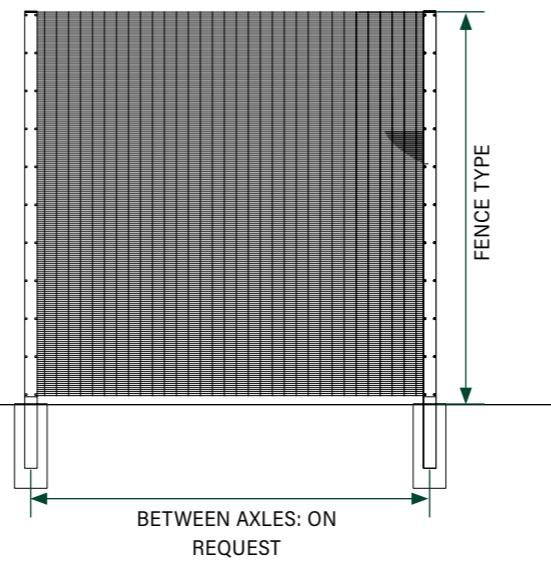

Assembly option

DEFENCE PLUS BRACKET OPTION

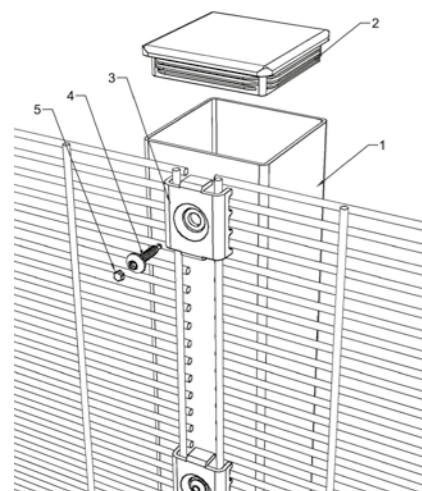

1. Post
2. Stopper
3. Bracket
4. Security screw
5. Star stopper

NUT AND BOLT OPTION

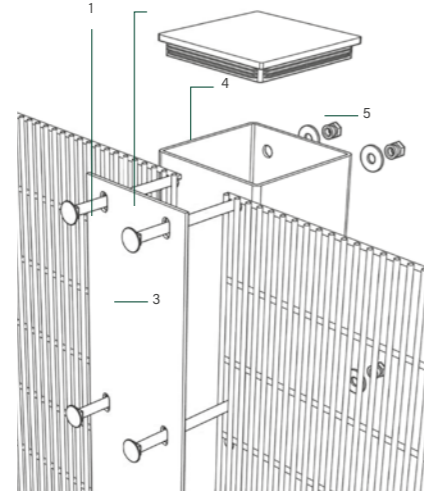

1. Defence Plus Mesh
2. Non-removable screw
3. Base
4. Special post
5. Non-removable female

BAYONET EXTENSION WITH BARBED WIRE

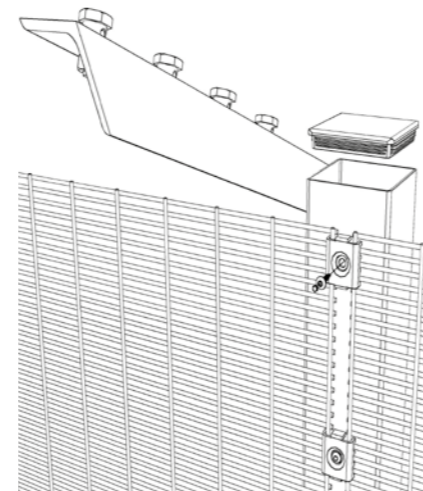

A bayonet extension with 4 rows of barbed wire can be mounted on the upper part of the fence. The bayonet is manufactured with a 50 mm "T" profile, and has the necessary fittings to be able to fix the barbed wire.



Stiffening system

These systems keep the frame perfectly aligned with the perimeter, increasing the rigidity of the fence and preventing deformation of the mesh due to pressure or impact.

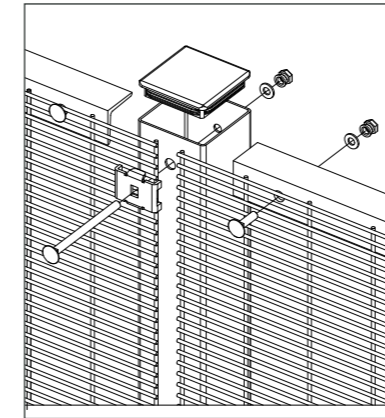

(A) ANGULAR
Angular profile stiffeners measuring 40x40x4mm Anchorages by means of non-detachable screws, metric M8x20mm

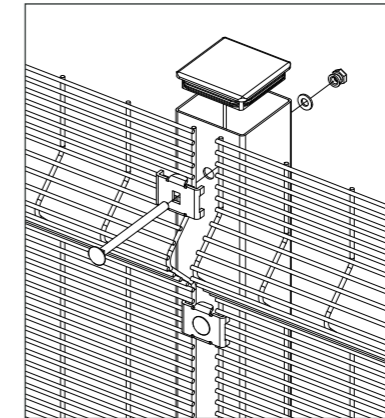

(B) FOLDS
The position and number of longitudinal folds will depend on the height of the fence.

Gates

Option of making swing system and sliding system gates filled with high-security Defence Plus panels.

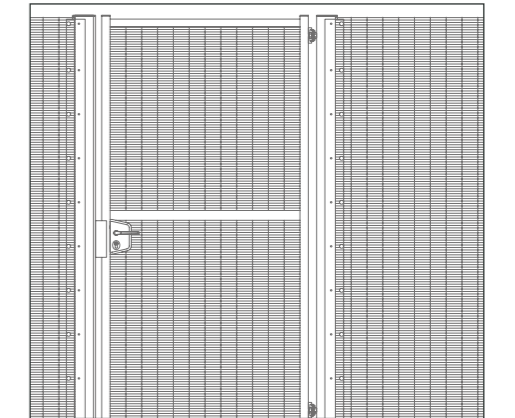

Anticorrosion coating

All the materials of the Defence Plus system are hot-dip galvanised and plastic-coated with the Rivisa® Protecline anticorrosion coating system.

- Minimum thickness: 100 microns
- Option of applying the Rivisa® Protecline Plus plastic coating, which prolongs the useful life of the materials
- Option of applying the Rivisa® Protecline Plus triple plastic coating, which prolongs the useful life of the materials
- Available in several colours from the Rivisa RAL chart. Colours:

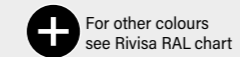
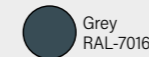
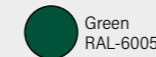

protecline

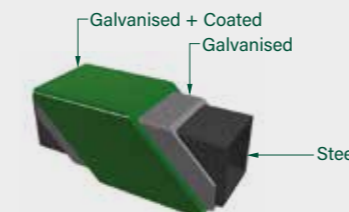

protecline PLUS

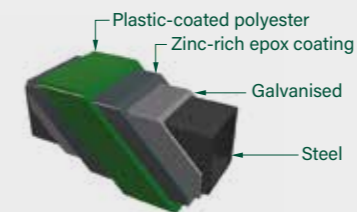

protecline TRIPLE

